

Control System with Uncertain Conditions, Inverted Pendulum Control and Liq.-Level Control



Junichi SUGAYA

Professor sugaya@sendai-nct.ac.jp

Affiliated Societies The Institute of Electrical Engineers of Japan, Japan Society for Design Engineering

Keywords Automation (20010), Control theory, Control systems (21040), Electric machinery, Power electronics (21010)

Research Topics

- Manufacturing development of two-axis liquid level control system with a liquid level sensor
- Research on swing up control of an inverted pendulum and advanced teaching materials
- Research supports for an economy with electric vehicles

Research Seeds

1. Inverted pendulum with inertia rotor (Fig. 1)

Stabilization of an inverted pendulum with the rotor is basic control as a posture control robot ASHIMO. However, an inverted pendulum with a rotor stands the pendulum using the reaction force generated by giving torque to the force point. Our purpose is mainly realizing the swing control.



Fig. 1 Swing type inverted pendulum.

2. Nonlinear liquid level control system with two-axis (Fig. 2)

We were performing studies or realizations of control models of various kinds using the concepts of PID optimal control and 2DOF PID control. These controllers are based on the robust control technology and are designed under the uncertain conditions with unexpected perturbation. It is the control purpose to suppress the oscillations of compound waves on a liquid surface.

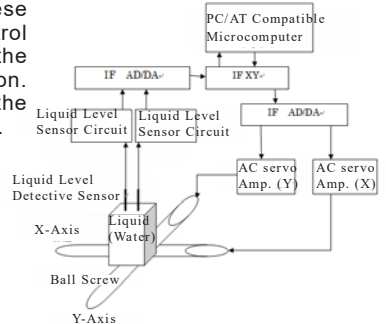

Fig. 2 Liquid level control system with X-Y.

3. Sequence control

We develop an inverted pendulum system as teaching materials for intermediate engineers by application of the sequence control technique. Some merit exists by which PLC has visual software because PLC can be treated with a CPU of the so-called sequence.

4. Research supports for eco-running electric vehicle (Fig. 3)

We have been developing a regenerative system to collect heat energy when braking in ultra-compact electric vehicles in a colleague's laboratory. Furthermore, Support has been given for evaluation and research mounted on an electric vehicle for an economy running competition. We participated in a competition at Sports Land SUGO in Miyagi.

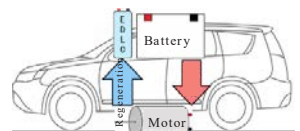

Fig. 3 Regenerative system in Eco-Run.

Related Technology

- Design and development of 2DOF liquid level control system
- Building and design of robust control systems with uncertain conditions
- Software development of the inertia rotor type control system design
- Various kinds of research support related to electric vehicle manufacturing